

Tap Sensor DETEC^{*} v2

Improve PPM level with the ultimate Tap Detection System



DETEC v2 is the most affordable "on the shelf" tap detection system ; making tap detection easy for both designers and final users.

DETEC completes PRONIC tapping solution by ensuring a total control of the tapping process during your production.

Simplifying your die design, this highly reliable device can easily be integrated in your future dies and/or your existing ones.

DETEC monitors closely the accuracy of your tapping operation, eliminating the need to sort your parts out because of broken taps, a pre-hole too small, or a miss feed.

What's new with DETEC v2 ?

Since 1st introduced in 2004, PRONIC has sold hundreds of DETEC. It has proved to be a great feature that takes In-Die tapping quality to the next level.

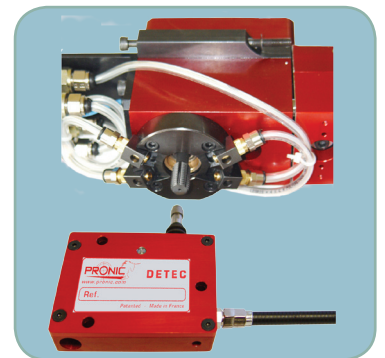

However, with existing users input, DETEC v2 gets even better:

- New stronger axis for heavy loads
- New design for simplified mounting
- Adjustable cable length for more flexibility to better fit your die design
- Easy access for servicing
- New compact proxy sensor with LED to visualize tap detection
- Simplified set-up
- Improved dust protection.

Principle

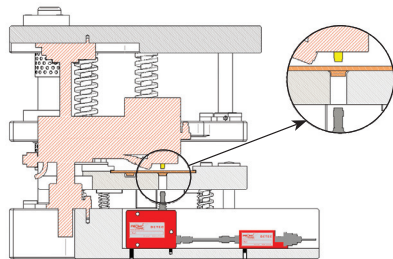

Top Dead Center

Though completely mechanical, DETEC includes a mechanical sensor that amplifies the motion of the tap to detect even the smallest movement.

Then, the signal is transmitted through a flexible hose to a mechanical receptor installed outside of the die.

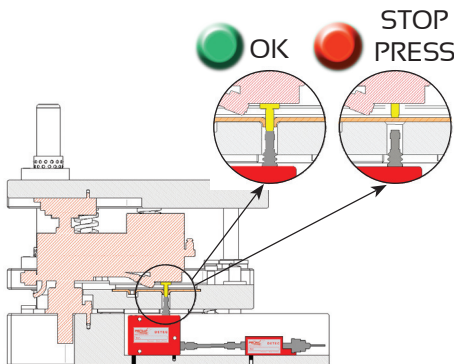

Bottom Dead Center

Easily mounted, the sensor and the "proxy switch/detector" are connected to your press control panel to stop the press if a problem occurs.

RELIABILITY

- Detects tap breakage, missfeed, wrong tap set-up and short tap travel
- Visual light (LED) when activated by the tap.
- 100% mechanical for reliability.
- Carbide reinforced probe.

SIMPLICITY

- Easy mounting
- Adjustable Cable length (2,36" - 29,53")
- Accessible set-up
- Limited servicing

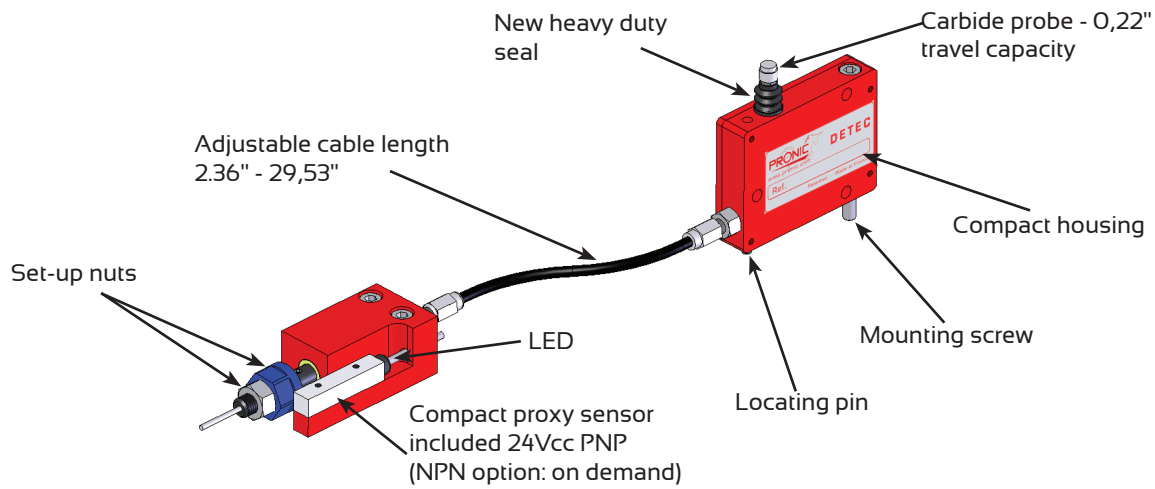

Dimensions

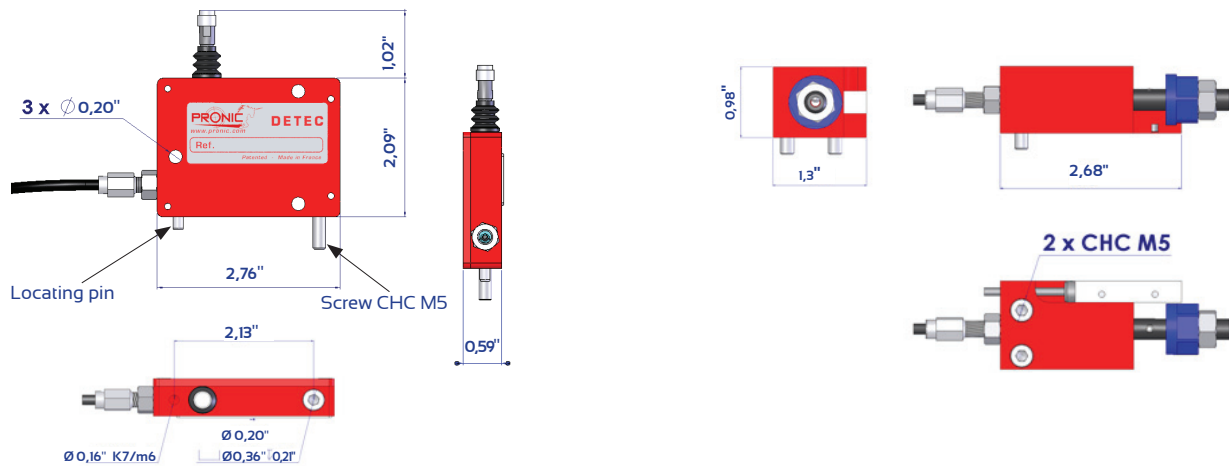

3 mounting configurations

On the pressure pad

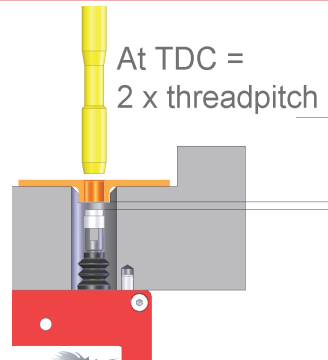
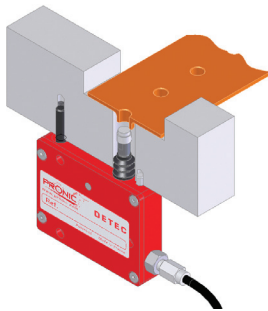

Distance device / extrusion

On the lower shoe (recommended mounting)

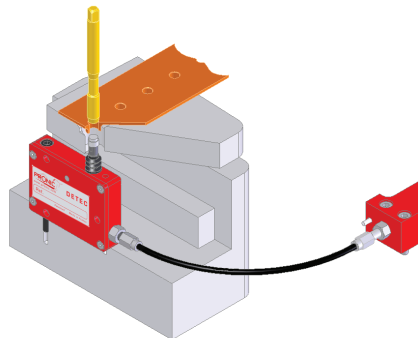

On the lower shoe (lateral fixation)

